

DRIVE▶RITE

AIR SUSPENSION SYSTEMS

Unit 626 Kilshane Avenue, North West Business Park, Ballycoolin, Dublin 15, Ireland

Telephone: +353 1 8612 632 Fax: +353 1 8612 647 email:info@driveriteair.com

Web: www.driveriteair.com

DR.02.013129

W21-760-3129

VOLKSWAGEN AMAROK 2010-Current

INSTALLATION INSTRUCTIONS



Table of Contents

Table of Contents	2
Introduction	3
IMPORTANT SAFETY NOTICE.....	3
Special Instructions for Air Connections.....	3
HARDWARE LIST.....	4
Step by Step Installation	5
Step 1: Remove the Bump Stop	5
Step 2: Install the Air fitting into the Air Spring.....	5
Step 3: Secure the Upper Bracket to the Air Spring.....	5
Step 4: Lower Bracket to Air Spring Assembly.....	6
Step 5: Air Spring Assembly-Upper Bracket to Chassis.....	6
Step 6: Air Spring Assembly-Lower Position	7
Step 7: Air Spring Assembly to Axle	8
Step 8: Routing the air tubing.....	9

Introduction

The purpose of this publication is to assist with the installation of the Drive-Rite Semi-Air air suspension kit.

It is important to read and understand the entire installation guide before beginning installation or performing any maintenance, service or repair. The information here includes a hardware list and step-by-step installation information.

Drive-Rite reserves the right to make changes and improvements to its products and publications at any time. Contact Drive-Rite at +353 1 8612 632 or visit us online at www.driveriteair.com for the latest version of this manual.

IMPORTANT SAFETY NOTICE

The installation of this kit does not alter the Gross Vehicle Weight Rating (GVWR) or payload of the vehicle. Check your vehicle's owner's manual and do not exceed the maximum load listed for your vehicle.

Gross Vehicle Weight Rating = the maximum allowable weight of the fully loaded vehicle (including passengers and cargo). This number — along with other weight limits, as well as tire, rim size and inflation pressure data — is shown on the vehicle's Safety Compliance Certification Label.

Payload: The combined, maximum allowable weight of cargo and passengers that the truck is designed to carry. Payload is GVWR minus the Base Curb Weight.

Precautions

Never exceed the maximum and minimum recommended pressure limits:

- Minimum Pressure 1 Bar (14.5 p.s.i)
- Maximum Pressure 7 Bar (100 p.s.i)

While it is possible to inflate the system in static mode to 7 Bar (100 p.s.i.), it should not be necessary to exceed operating pressure in the region of 3.5 Bar (50 p.s.i.) at vehicle full GVW. This kit should not be used to carry any greater load than manufacturers stated GVW.

To avoid damage to airsprings – When the kit has been installed, please ensure there is adequate clearance (25mm) around the airspring so the airspring does not come in contact with any other parts.

NEVER DRIVE WITH DEFLATED AIRSPRINGS

Special Instructions for Air Connections

- To cut the tubing correctly an appropriate cutter must be used (not scissors)



- When inserting the tubing into the connection, it must be pushed in approximately 14mm until a 'click' is heard.
- To remove the tube, you must push the flange in on the connection and at the same time pull the tube. (No tool is necessary.)

- **ATTENTION**, when a tube is removed it is important to trim 14mm from the end before reconnection.
- It is advisable that LOCTITE or similar sealant be used on the threaded fittings.

 **HARDWARE LIST**

Part Name	Quantity	Picture/Description	Part #
Upper Brackets	2		DRV-7480
Lower Bracket	2		DRV-7374
Chassis Support	2		DRV-7512
Axle Strap	2		DRV-7375
M12x1.75-110mm Hex head Bolt	2	Upper Bracket to Chassis	
M12 Penny Washers	4	for M12 Bolt	0128
M12 Nyloc Nut	2	for M12 Bolt	0141
M8 Flat Washer	4	for Inflation Valve	0007
M10x1.5-100 Hex Head bolt	4	Upper Bracket to Chassis	3871
M10 x 120 Countersunk Bolt	4	Axle Strap to Lower Bracket	
M10 Locknuts	8	For M10 Countersunk Bolt	0034
M10 Flat Washers	12	For M10 Countersunk Bolt	0079
Cable Ties	10	For M10 Countersunk Bolt	9037
M10 Countersunk Bolt	2	Lower Bracket to Air Spring	3845
267C Air Springs	2		6694
6mm Tubing	5m		1321-1M
M10 Flange Bolt	4	Upper Bracket to Air Spring	3848
6mm Elbow	2		3047
6mm Inflation valve	2		0155
6mm Tee piece	1		3703
Thermal Sleeves	2		0899
6mm Compression Joiner	2	For Metric to Imperial Tubing	0190

Step by Step Installation

↘ Step 1: Remove the Bump Stop

Remove the bump stop circled with the broken line.

Note:

The style 267 air spring used in this kit acts as a bump stop when deflated. The rubber folds in on itself and this prevents metal to metal contact. For this reason the original bump stop is no longer necessary.



↘ Step 2: Install the Air fitting into the Air Spring

Insert the ¼" to 6mm Elbow fitting into the Air Spring as shown in the image.

To help to ensure a tight seal, it is recommended that sealant is used, but it is not required.



↘ Step 3: Secure the Upper Bracket to the Air Spring

Secure the air spring to the upper bracket using 2 x M10 Flange Bolts.

Torque to approx. 28Nm



Step 4: Lower Bracket to Air Spring Assembly

Bolt the lower bracket to the assembly using the M10 countersunk bolt.

Ensure the orientation is correct; The tab in the Lower bracket should be on the same side as the 'P'-Clip in the Upper Bracket, as in the image to the right.

Torque to approx. 28Nm

The circled tab on the lower bracket should be facing inboard.



Step 5: Air Spring Assembly-Upper Bracket to Chassis

Locate the Air Spring assembly onto the chassis ensuring that the smaller 'front' and 'rear' flanges are sitting inside the bump stop bracket.

The Air fittings should be facing inboard.

Ensure that the Upper bracket is sitting fully against the chassis.

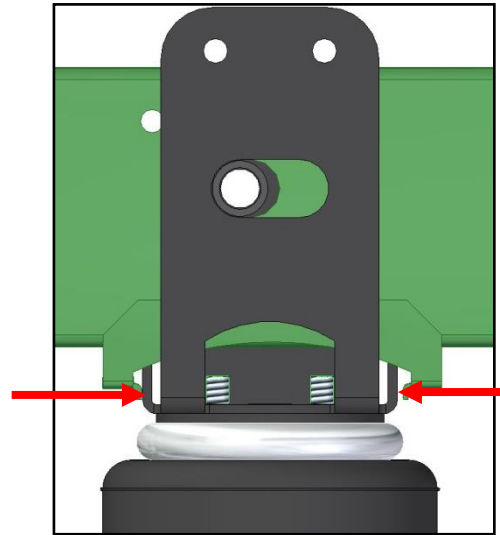

Use the supplied M10x1.5-100 hex bolts, M10 washers and nyloc nuts to tighten the bracket above the chassis. (Circled in the image with the broken line).

Do not torque at this point.

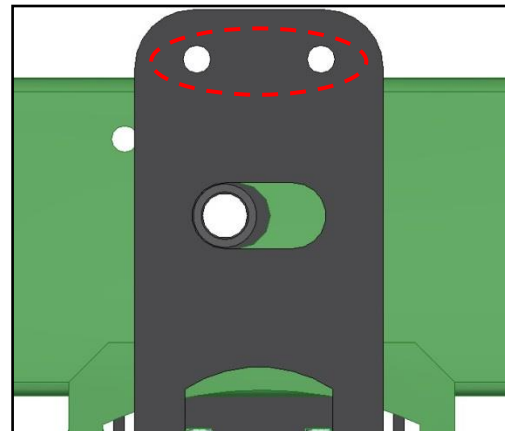

Place the Chassis Support into the hole on the inboard face of the Upper Bracket. Secure this in place using the supplied M12 x 110 hex bolt, M12 penny washers and M12 nyloc nuts.

Torque to approx. 70Nm.

At this point **torque the M10x1.5-100 bolts to the approx. 40Nm.**

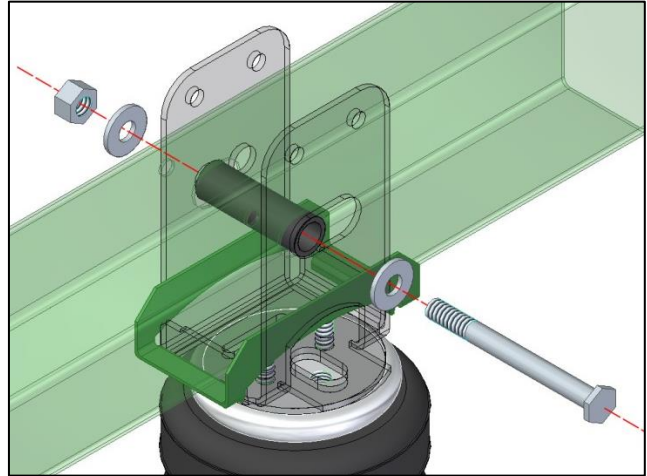

↘ Step 6: Air Spring Assembly-Lower Position

The Lower Bracket is situated between the brake line bracket (Circled with the broken line) and leaf-spring stack (Circled with the solid line). This prevents side to side movement of the bracket.

The Lower bracket must be sitting flush onto the axle and not on the brake line bracket.

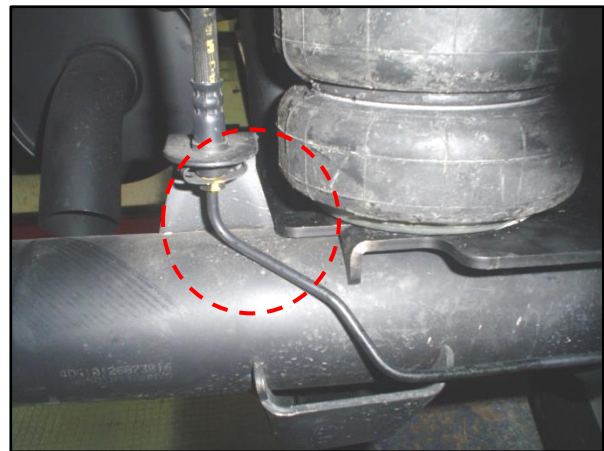

The Lower Bracket must rest in between the U-Bolts. This prevents the bracket from twisting on the axle.

Ensure that the bracket is fully in place and not tilted.

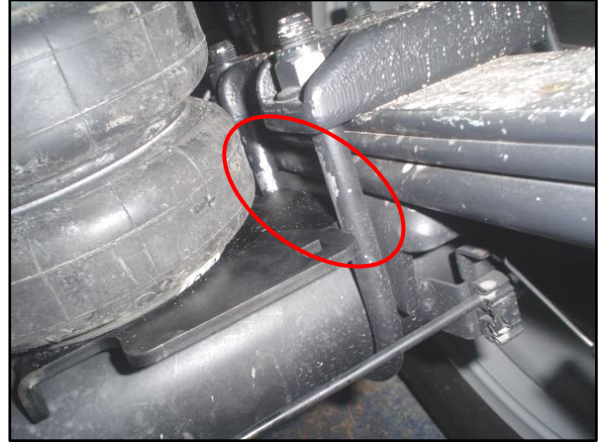

↘ Step 7: Air Spring Assembly to Axle

Place an axle strap under the axle in line with the square cut outs on the Lower Bracket and fix the Lower Bracket to the Axle Strap using the M10x120 Countersunk bolts, flat washers and nyloc nuts.

Tighten the countersunk bolts evenly. ***Do not over tighten as this will cause the lower bracket to distort.***

When tightened the length of thread on the left bolt below the nyloc nut should be the same as the thread length on the right bolt below the nyloc nut.

Torque to approx. 38Nm.

Ensure the brake line does not come into contact with the countersunk bolt.



↘ Step 8: Routing the air tubing

Cut a long length of tubing in order to connect the valve to the nearest air spring. Do the same for the opposite side. Choose whether you want separate inflation valves for each side or one valve common to both sides using the T shaped connector. Use the nylon ties provided to tie the tubing up into a safe position.



When cutting the air tube, it is vital that the tube is not cut at an angle. This could cause an air leak. It is recommended that a tube cutter or a sharp blade.



Drill an 8mm (5/16") hole and mount the inflation valve as shown in the diagram, pushing the valve through the hole from behind and attaching with 2 washers and a nut.

Cut the air tube to length, making sure the end is cut squarely, and push the end as far as possible into the back of the inflation valve.

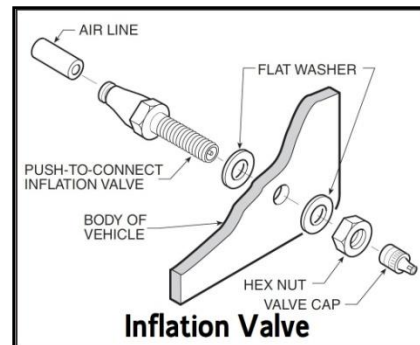

IMPORTANT:

- Attach all tubing securely to the underneath of the vehicle using nylon ties.
- Do not attach to brake lines.
- Protect the tube with the sleeves provided where there are any sharp edges or sources of heat.

Examination:

After assembly, inflate air springs and check all mounting bolts are tight. Screw all connections tight again. It must be ensured that the mounting brackets cannot move. If the plates touch the brake hose at the air springs, then these must be moved by suitable means.

If the vehicle is fitted with ABS and no LSV, then no brake adjustment is required.

For vehicles without ABS and have a LSV fitted you will need to fit the brake modulation kit.

For vehicles without ABS, please contact us on +353 1 8612632.



DRIVE RITE

AIR SUSPENSION SYSTEMS

Unit 626 Kilshane Avenue, North West Business Park, Ballycoolin, Dublin 15, Ireland
 Telephone: +353 1 8612 632 Fax: +353 1 8612 647 email: info@driveriteair.com
 Web: www.driveriteair.com

