

# **DRIVE▶RITE**

## **AIR SUSPENSION SYSTEMS**

Unit 626 Kilshane Avenue, North West Business Park, Ballycoolin, Dublin 15, Ireland

Telephone: +353 1 8612 632 Fax: +353 1 8612 647 email:info@driveriteair.com

Web: [www.driveriteair.com](http://www.driveriteair.com)

### **DR.02.014004**

**Toyota Hilux**



### **INSTALLATION INSTRUCTIONS**

# Table of Contents

<b>Table of Contents</b> .....	<b>2</b>
<b>Introduction</b> .....	<b>3</b>
IMPORTANT SAFETY NOTICE .....	3
Special Instructions for Air Connections .....	3
<b>Kit Contents</b> .....	<b>4</b>
HARDWARE LIST .....	4
<b>Step by Step Installation</b> .....	<b>5</b>
Step 1: Remove the Bump Stop .....	5
Step 2: Lower Bracket to Air Spring .....	5
Step 3: Upper Bracket to Air Spring .....	5
Step 4: Fit Air Spring Assembly to Vehicle .....	6
Step 5: Routing the Air Tubing .....	7

# Introduction

The purpose of this publication is to assist with the installation of the Drive-Rite Semi-Air air suspension kit.

It is important to read and understand the entire installation guide before beginning installation or performing any maintenance, service or repair. The information here includes a hardware list and step-by-step installation information.

Drive-Rite reserves the right to make changes and improvements to its products and publications at any time. Contact Drive-Rite at +353 1 8612 632 or visit us online at [www.driveriteair.com](http://www.driveriteair.com) for the latest version of this manual.

## IMPORTANT SAFETY NOTICE

The installation of this kit does not alter the Gross Vehicle Weight Rating (GVWR) or payload of the vehicle. Check your vehicle's owner's manual and do not exceed the maximum load listed for your vehicle.

**Gross Vehicle Weight Rating** = the maximum allowable weight of the fully loaded vehicle (including passengers and cargo). This number — along with other weight limits, as well as tire, rim size and inflation pressure data — is shown on the vehicle's Safety Compliance Certification Label.

**Payload:** The combined, maximum allowable weight of cargo and passengers that the truck is designed to carry. Payload is GVWR minus the Base Curb Weight.

### Precautions

Never exceed the maximum and minimum recommended pressure limits:

- Minimum Pressure            1 Bar (14.5 p.s.i.)
- Maximum Pressure           7 Bar (100 p.s.i.)

*While it is possible to inflate the system in static mode to 7 Bar (100 p.s.i.), it should not be necessary to exceed operating pressure in the region of 3.5 Bar (50 p.s.i.) at vehicle full GVW. This kit should not be used to carry any greater load than manufacturers stated GVW.*

*To avoid damage to airsprings – When the kit has been installed, please ensure there is adequate clearance (25mm) around the airspring so the airspring does not come in contact with any other parts.*

## NEVER DRIVE WITH DEFLATED AIRSPRINGS

## Special Instructions for Air Connections

- To cut the tubing correctly an appropriate cutter must be used (not scissors)



- When inserting the tubing into the connection, it must be pushed in approximately 14mm until a 'click' is heard.
- To remove the tube, you must push the flange in on the connection and at the same time pull the tube. (No tool is necessary.)
- **ATTENTION**, when a tube is removed it is important to trim 14mm from the end before reconnection.
- It is advisable that LOCTITE or similar sealant be used on the threaded fittings.

# Kit Contents

## ↓ HARDWARE LIST

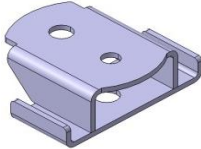
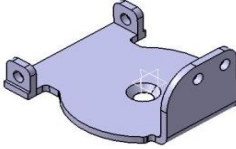
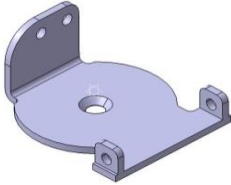
Name	Qty	Picture/Description	Part No.
Lower Bracket	2		DRV-7590
Upper Left Bracket	1		DRV-7706
Upper Right Bracket	1		DRV-7705
M10 Hex Nut	4		
M10 x 30 Hex Head Bolt	4		
M8 X 110 Cap Head	2		
M8 Washer	4		
M8 Nyloc Nut	4		
Cable Ties	15		
Air Spring	2		7936/ 6397
3/8 X 3/4 Countersunk Bolt	2	For use with 6397	6034
<b>M10 X 20 Countersunk Bolt</b>	<b>2</b>	<b>For use with 7936</b>	<b>3845</b>
M16 Washer	2		0125
<b>M16 Spring Washer</b>	<b>2</b>	<b>For use with 7936</b>	<b>3898</b>
<b>M16 Half Nut</b>	<b>2</b>	<b>For use with 7936</b>	<b>4002</b>
5/8 UNF Half Nyloc Nut	2	For use with 6397	3332
6mm Tubing	5		1364-1MR
<b>1/8 - 6mm Elbow</b>	<b>2</b>		<b>3618</b>
<b>6mm Tee Piece</b>	<b>1</b>		<b>3666</b>
<b>6mm Inflation Valve</b>	<b>2</b>		<b>3660</b>

# Step by Step Installation

## Step 1: Remove the Bump Stop

Loosen the rear axle u-bolts enough to remove the bump stop from the leaf pack.

**NOTE-** The u-bolts are re used to fit the lower bracket.

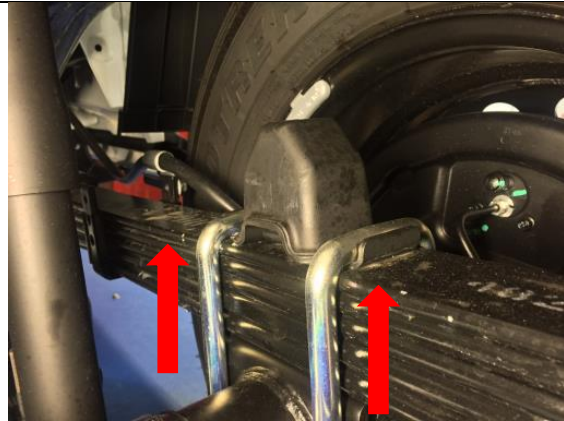

## Step 2: Lower Bracket to Air Spring

Secure Lower Bracket to air spring using nut and washer provided. Install air fitting at this time.

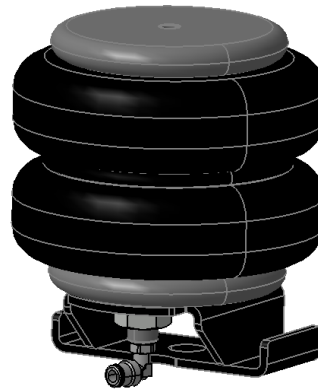
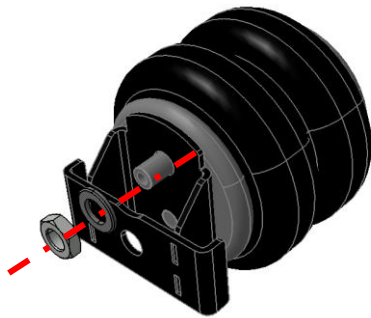

## Step 3: Upper Bracket to Air Spring

Fasten the upper bracket to the airbag using the supplied countersunk bolt. Torque to 20 Nm.

Orientate the bracket as shown, with the upturned flange on the upper bracket to the same side as the long combo stud on the bottom of the bag.

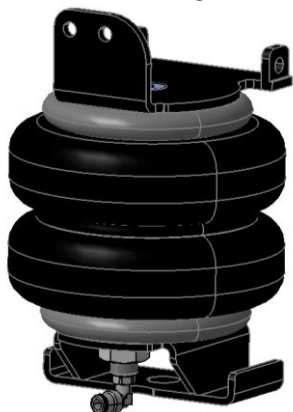

RHS Shown

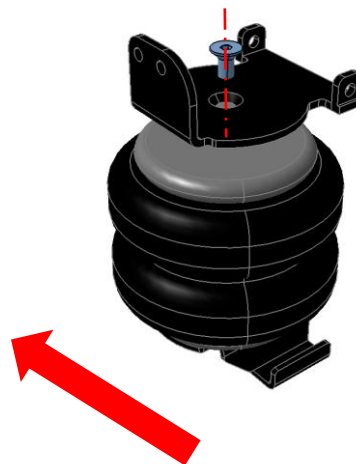

FRONT OF VEHICLE

**Step 4: Fit Air Spring Assembly to Vehicle**

Insert the air spring assembly into the old bump stop location. Ensure air fitting is facing inboard. **Torque U-bolts to 68Nm.**

**Tip: When tightening the u-bolts, tighten in diagonal pairs.**

Using the M8 Cap Head Bolt, M8 Washers & M8 Nyloc nut provided secure the upper bracket to the bump stop striker plate of the vehicle. **Torque to 25 Nm.**

Ensure correct assembly is being used for each side of the vehicle as determined in Step 3.

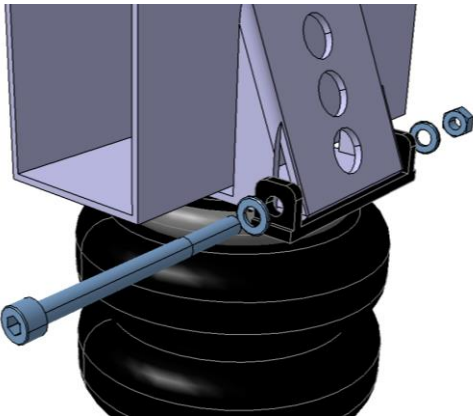
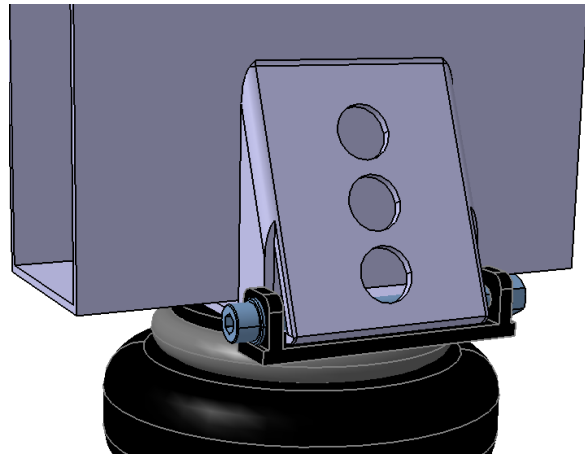

Turn M10 x 30 hex head bolt until it is finger tight against chassis face. Lock the M10 bolt by tightening the M10 nut to the bracket.

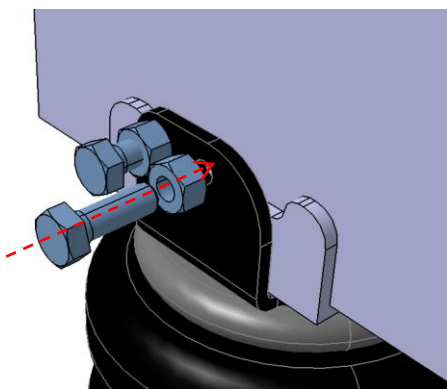

**Note:** Before tightening M10 nut, ensure the upper bracket seats completely against the bump stop striker.

**Bracket sitting flush with striker plate**

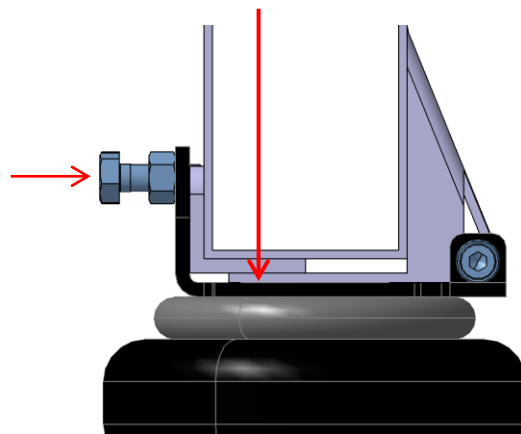

Ensuring that the hex bolts sit into the groove in the striker plate and **not** push into the striker plate itself.

## Step 5: Routing the Air Tubing

Cut a long length of tubing in order to connect the valve to the nearest air spring. Do the same for the opposite side. Choose whether you want separate inflation valves for each side or one valve common to both sides using the T shaped connector. Use the nylon ties provided to tie the tubing up into a safe position.



When cutting the air tube, it is vital that the tube is not cut at an angle. This could cause an air leak. It is recommended that a tube cutter or a sharp blade be used.



Drill an 8mm (5/16") hole and mount the inflation valve as shown in the diagram, pushing the valve through the hole from behind and attaching with 2 washers and a nut.

Cut the air tube to length, making sure the end is cut squarely, and push the end as far as possible into the back of the inflation valve.

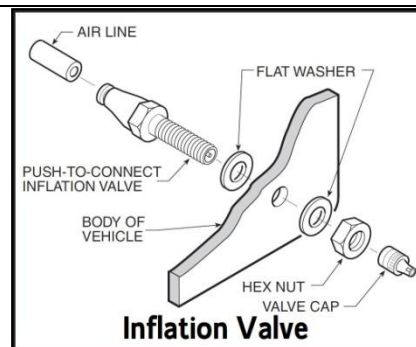

### IMPORTANT:

- Attach all tubing securely to the underneath of the vehicle using nylon ties.
- Do not attach to brake lines.
- Protect the tube with the sleeves provided where there are any sharp edges or sources of heat.
- Ensure all fittings are fastened to recommended torque.

### Examination:

After assembly, inflate air springs and check all mounting bolts are tight. Screw all connections tight again. It must be ensured that the mounting brackets cannot move. If the plates touch the brake hose at the air springs, then these must be moved by suitable means.

